

# Safety of a High-Efficiency Electrical Fence Energizer

Mark W. Kroll, PhD, *FIEEE*; Peter E. Perkins, MSEE, *LFIEEE*; Hugh Pratt, PhD; Edward Stuart, *Member IEEE*; J. Bury, *Member IEEE*; Dorin Panescu, PhD, *FIEEE*

**Introduction:** Our primary goal was to evaluate the performance of a new high-efficiency electric fence energizer unit using resistive load changes. Our secondary goal was to test for compliance with the classical energy limits and the newer charge-based limits for output.

**Methods:** We tested 4 units each of the Nemtek Druid EFE with 2 channels each. We used a wide load-resistance range to cover the worst-case scenario of a barefoot child making a chest contact (400  $\Omega$ ) up to an adult merely touching the fence (2 k $\Omega$ ).

**Results:** The energy output was quite consistent between the 8 sources. Even at the lowest resistance, 400  $\Omega$ , the outputs were well below the IEC 60335-2-76 limit of 5 J/pulse. The charge delivered was also quite consistent. Even at the lowest resistance, 400  $\Omega$ , the outputs (679  $\pm$  23  $\mu$ C) were well below the proposed limits of 4 mC for short pulses.

**Conclusions:** The high-efficiency electric fence energizers satisfied all relevant safety limits. Charge, energy, voltage, and current outputs are consistent between channels and distinct units.

## INTRODUCTION

Electric fence technology allows for economical and safe control of animals and humans as opposed to barbed or concertina wire which can cause injury. They use a painful brief shock intended to be well below the threshold for VF (ventricular fibrillation) and thus unable to electrocute a human being.[1] The traditional EFE (electric fence energizer) charged a capacitor and then dumped the capacitor energy into the primary of a transformer.[2] The secondary of the transformer then delivered its output to the electric fence wires. Such open-loop systems are affected by arcing (to vegetation or between wires) which can significantly reduce the charge delivered to the fence. Simply increasing the output is unacceptable due to safety concerns and there have been pediatric fatalities due to noncompliant fences.[3, 4] There are US and international safety standards governing EFEs.[5-7]

The traditional EFE output stages are not optimally efficient — in terms of energy and materials — due to the energy-material tradeoffs in the large capacitor and transformer output stage. The tested design (shown in Figure 1) uses diode current-steering to significantly reduce the size of the capacitor and transformer. The 30  $\mu$ F energy-storage capacitor and the 16  $\mu$ H series inductor give a resonant frequency of  $\sim$ 7 kHz or a period of  $\sim$ 60  $\mu$ s. This is significantly underdamped as there is minimal resistance in the circuit (300 m $\Omega$  from PC board tracings). A 2<sup>nd</sup> higher frequency resonant circuit is formed by the inductor and the 12  $\mu$ F capacitor; this causes the 2<sup>nd</sup> peak superimposed onto the main discharge curve. The

diode across the transformer primary eliminates the longer low amplitude reverse flow of current through the transformer and so keeps the output pulse shorter in duration as well as eliminating useless energy delivery cancelling charge from the main discharge pulse. See Figure 2. Since many present EFE standards still include the arbitrary 5 J/pulse energy limit, reducing the delivered energy is important for regulatory reasons. This design is able to use smaller and lighter inductors and capacitors without having the charge cancellation that would be otherwise seen. Due to the classical misunderstanding that energy causes sensation, this monopolarity feature was often not appreciated in the past.

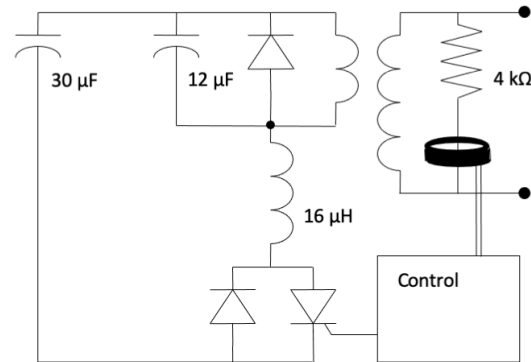

Figure 1. Output stage of tested energizer.

Feedback control also allows for significant energy efficiency gains. The design of a closed-loop EFE is non-trivial due to the load nonlinearities, transformer saturation, and the isolation of the high-voltages. The output load has capacitance, inductance, and transmission-line characteristics making modeling somewhat complex.[8, 9] With line distances  $>$  1 km the input impedance of a linear electric fence approaches that of free space (377  $\Omega$ ) with a reflected impedance near 0  $\Omega$ . In addition, arcing to vegetation introduces nonlinearities while arcing to ground (or to a return wire) can introduce negative dynamic resistance which makes traditional feedback control impossible.

We evaluated the performance of the Nemtek Druid™ units with APT (Adaptive Power Technology) whose loaded waveforms are given in Figure 2. Upon initialization, it charges the output capacitors to a level that are expected to approximately generate a 4 kV pulse after passing thru a pulse

<sup>1</sup> M. W. Kroll is an Adjunct Professor of Biomedical Engineering at the University of Minnesota, Minneapolis, MN (e-mail: [mark@kroll.name](mailto:mark@kroll.name)). Dr. Kroll is a consultant to Amarok. P. Perkins is an independent consultant. [peperkinspe@cs.com](mailto:peperkinspe@cs.com) Hugh Pratt, PhD, is Secretary of CPLSO

Edward Stuart ([estuart@amarok.com](mailto:estuart@amarok.com)) and J Bury ([jbury@amarok.com](mailto:jbury@amarok.com)) are employees of Amarok. D. Panescu is Chief Technical Officer, Vice President R&D, HeartBeam, Inc. (e-mail: [panescu\\_d@yahoo.com](mailto:panescu_d@yahoo.com)).

transformer. The actual voltage output is then measured, and this is used to calibrate the system and then the following pulses are delivered with peak voltages of 8.5-9.5 kV for a largely open circuit. In case of arcing, the voltage waveform is distorted from that seen in Figure 2 and the system recognizes this and reduces the peak voltage until the arcing ceases. This feature was not tested in our study.

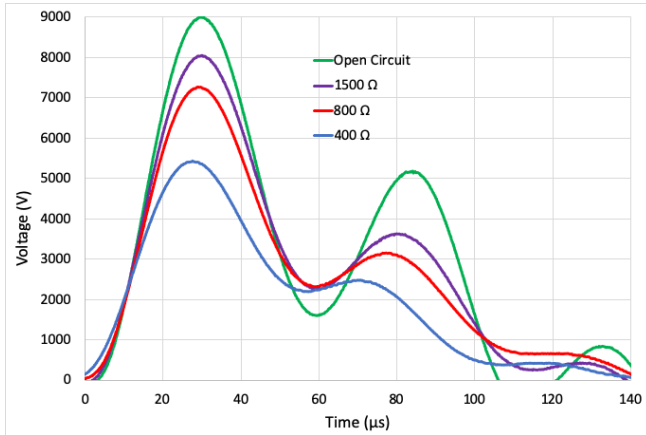

Figure 2. Typical output voltage waveforms for various loads.

For a closed-loop design a feedback signal from the energizer’s output terminals is required. Although a simple resistor voltage-divider network can provide an accurate feedback signal, this is not practical due to isolation specifications which are required by the electric fence safety standards. The units tested sampled the output voltage by running it thru a high-voltage non-inductive 4 kΩ resistor. The current thru the resistor was, in turn, sampled by a current transformer (black ring in Figure 1) to provide isolated feedback to the control circuitry.

Present EFE safety standards are based on a 5-joule energy limit per pulse. However, energy heats while charge stimulates and newer safety standards, for general applications, are now being based on the delivered charge.[10] The charge is more dependent on the load resistance and thus we sought to evaluate this technology vs. the newer charge limits. We used a wide load-resistance range to cover the worst-case scenario of a barefoot child making a chest contact (400 Ω) up to an adult merely touching the fence (2 kΩ).[11]

Our primary goal was to evaluate the performance of the new high-efficiency feedback-controlled EFE units with load changes. Our secondary goal was to test for compliance with the classical energy limits and the newer charge-based limits for output.

#### METHODS

We constructed a 1000:1 voltage divider using a 1 MΩ high-voltage low inductance Ohmite MOX-3N resistor with a 30 kV pulse rating in series with 1001 Ω. The load resistance was selectable over 400, 500, 600, 700, 800, 1k, 1.2k, 1.5k, and 2 kΩ by use of the schematic shown in Figure 3. The load resistances were made up from Ohmite model OY series 100 Ω and 1 kΩ noninductive ceramic resistors rated for 20 kV and 70 J of capacitive discharge. Series trimming was done with smaller-value carbon resistors. The open circuit voltage

was measured by removing the jumper going to a load resistor. Since the tested EFEs all had a 4 kΩ output resistor, the output-stage transformer was never truly operating into an open-circuit load.

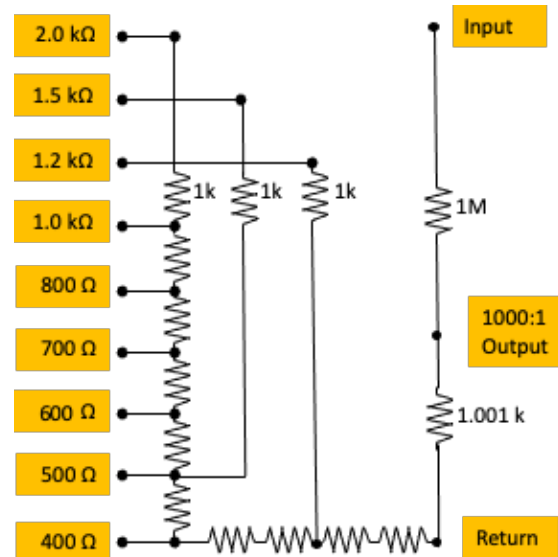

Figure 3. Voltage divider and load resistors. Unlabeled resistors are 100 Ω.

All resistance values were verified to be within 1% of the desired values by measurement with a Flexzion VC8145 5-digit meter which was in turn calibrated to a Vishay (0.1% 500 Ω precision resistor.) Voltage values were recorded by a calibrated Siglent SDS1202X digital storage oscilloscope sampling at 1 ns intervals.

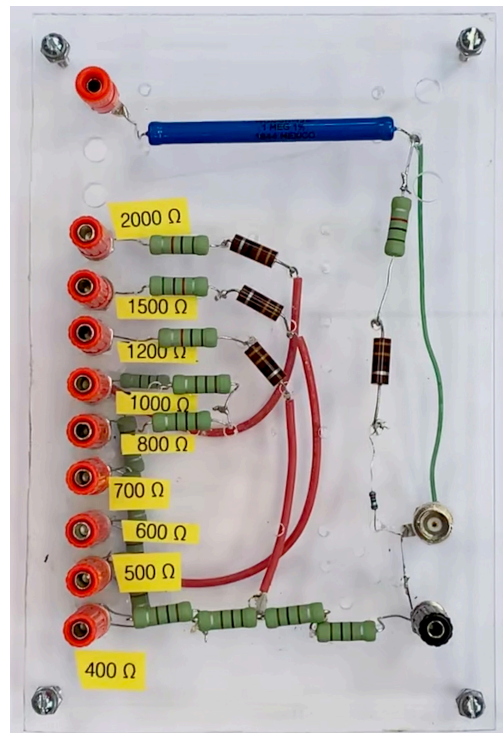

Figure 4. Voltage divider and load resistors.

A total of 4 Nemtek Druid™ EFE units were tested. Since each unit has 2 individual outputs, there were 8 sources tested in total. For determination of the peak voltage and current, the instantaneous voltages were boxcar averaged over 200 samples (200 ns duration) to reduce noise artifact.

### RESULTS

The energy per pulse output was quite consistent between the 8 sources as shown in Figure 5. Even at the lowest resistance, 400 Ω, the outputs were well below the IEC 60335-2-76-limit of 5 J/pulse.

There is a consistent transition seen between 1 kΩ and 1.2 kΩ as the system shifts from open loop to feedback control. For loads ≤ 1.1 kΩ, the output voltage is limited passively by the maximum energy in the main storage capacitor.

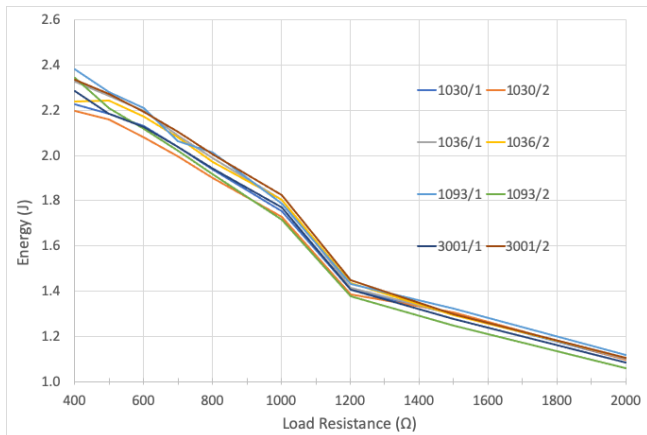

Figure 5 Energy per pulse as function of load resistance.

The charge delivered was quite consistent between the 8 sources as shown in Figure 6. Even at the lowest resistance, 400 Ω, the outputs were well below the proposed new limits of 4 mC/pulse.[10]

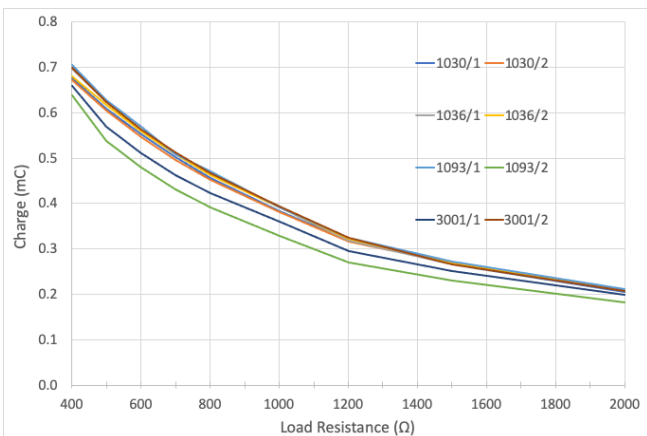

Figure 6 Charge per pulse as function of load resistance.

The peak voltage delivered was also quite consistent between the 8 sources as shown in Figure 7. None exceeded the specified 9.7 kV maximum even with an open circuit. Again, there is a consistent control transition seen between 1 kΩ and 1.2 kΩ as control shifts from passive to active feedback. The

feedback adjustment converged very rapidly and appeared to settle typically within a single 2<sup>nd</sup> pulse after a load change.

Linear regression modeling found that the peak voltage was roughly modeled as an internal  $9154 \pm 58$  V source in series with a  $224 \pm 54$  Ω equivalent series resistance.

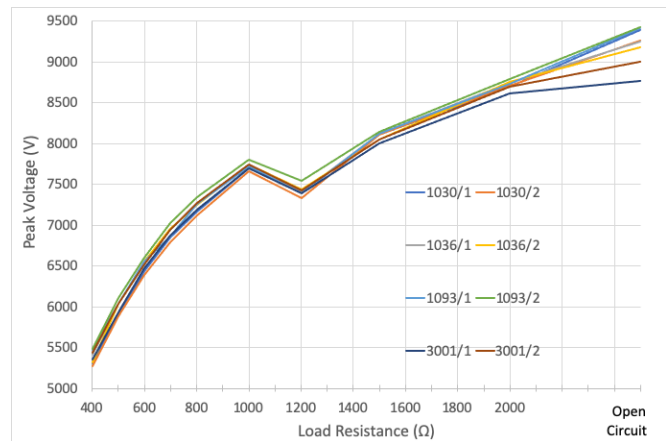

Figure 7. Peak voltage as function of load resistance.

The peak current delivered was impressively consistent between the 8 sources as shown in Figure 8.

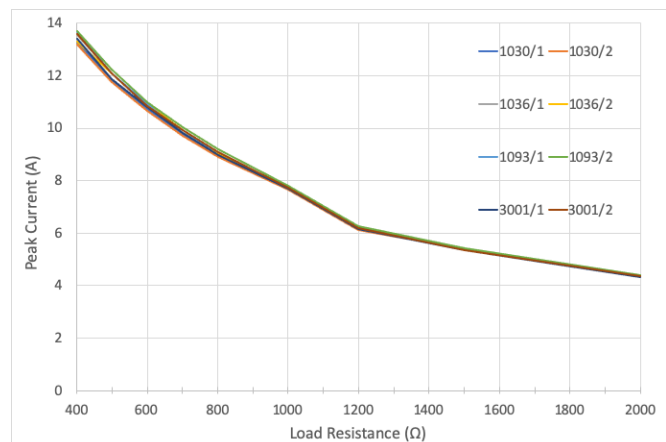

Figure 8. Peak current as function of load resistance.

### DISCUSSION

We believe that this is the first paper to examine the performance and safety of advanced high-efficiency digital feedback-controlled electric fence energizers. All units tested satisfied all relevant safety limits. Charge, energy, voltage, and current outputs were consistent between both channels and distinct units.

The ubiquitous electric fence is essential to modern agriculture and has saved a great many lives by reducing the number of livestock automobile collisions.[12-16] They also provide safe protection against criminal activity. Modern safety standards such as IEC 60335-2-76 and UL 69 have certainly played a role in this positive result.[5, 17] However, the safety standards are essentially based on energy and power (RMS current) considerations, which have limited direct relationship to cardiac effects.

Upcoming safety standards, for short pulses, will be based on the more scientific charge.[10] With great precision, UL researcher Whittaker proposed a charge-based limit, of 4 mC, back in 1939.[18] Because of electrocutions from AC electric fences, impulse-generating electric fence energizers became very popular in the 1930. Many government agencies and standards organizations then adopted charge limits to levels deemed safe.[1] The Underwriter's Laboratories (USA) proposed 4 mC as a safe impulse.[18] The Industrial Commission of Wisconsin (a USA state important for dairy production) and the U.S. National Bureau of Standards adopted 3 mC as the safe level. Most countries adopted 3 mC as the safe level including Finland, Denmark, Great Britain, and France.[1] Sweden used a 2.5 mC level and the C.E.E (IEC predecessor) also proposed 2.5 mC.[1] The IEC 60335 standard replaced the various country standards and eventually dropped the charge-based limit in 1989 in favor of a pure-energy limit.

Thus, the international standards community once had scientifically-sound *charge-based* limits for electrical impulses. Unfortunately, this understanding was somehow lost and the impulse limits became associated with the less-relevant energy and power.[10]

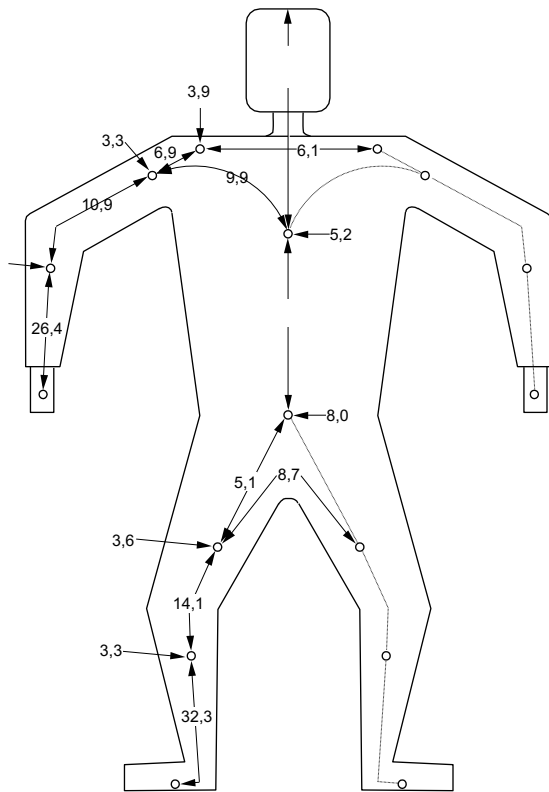

Figure 9. Body part contributions to resistance.

Based on the 37% contribution of the arm to the typical body resistance, we discounted the median 775  $\Omega$  high-voltage impedance to 488  $\Omega$  as given by our Figure 9 taken from IEC 60479-1.[6] To include the worst-case scenario of a barefoot

child contacting a fence at chest height, we further deducted the 9.9% (for shoulder to center-trunk) so the resistance would be 409  $\Omega$  and thus we elected to test down to a 400  $\Omega$  load.

### LIMITATIONS

We did not evaluate the performance of these units with capacitive or inductive loads. We did not evaluate the performance with long lines.

### CONCLUSIONS

The digitally controlled feedback electric fence energizer tested satisfied all relevant safety limits. Charge, energy, voltage, and current outputs are consistent between channels and distinct units.

### REFERENCES

- [1] C. F. Dalziel, "Electric fences-their hazards, types, regulations, and safe application," *Transactions of the American Institute of Electrical Engineers*, vol. 69, no. 1, pp. 8-15, 1950.
- [2] M. G. B. De Martino, F. S. Dos Reis, and G. A. Dias, "An electric fence energizer design method," in *2006 IEEE International Symposium on Industrial Electronics*, 2006, vol. 2, pp. 727-732: IEEE.
- [3] M. Burke, M. Odell, H. Bouwer, and A. Murdoch, "Electric fences and accidental death," *Forensic Sci Med Pathol*, vol. 13, no. 2, pp. 196-208, Jun 2017.
- [4] L. Stallones, "Fatal unintentional injuries among Kentucky farm children: 1979 to 1985," *The Journal of Rural Health*, vol. 5, no. 3, pp. 246-256, 1989.
- [5] Underwriters Laboratories, "UL 69: Electric fence controllers," June 2003.
- [6] IEC, "Household and similar electrical appliances – Safety – IEC 60335-2-76: Particular requirements for electric fence energizers," *International Electrotechnical Commission*, 2006.
- [7] M. W. Kroll, P. E. Perkins, and D. Panescu, "Electric fence standards comport with human data and AC limits," *Conf Proc IEEE Eng Med Biol Soc*, vol. 2015, pp. 1343-8, Aug 2015.
- [8] D. Thrimawithana and U. Madawala, "Modeling pulse reflections due to multiple discontinuities on electric fence structures," in *2008 IEEE International Conference on Industrial Technology*, 2008, pp. 1-6: IEEE.
- [9] D. J. Thrimawithana and U. K. Madawala, "Generalised mathematical model for high-voltage pulse propagation along electric fence structures," *IET Science, Measurement & Technology*, vol. 5, no. 3, pp. 109-116, 2011.
- [10] M. W. Kroll, D. Panescu, R. Hirtler, M. Koch, and C. J. Andrews, "Dosimetry for Ventricular Fibrillation Risk with Short Electrical Pulses: History and Future.," *Conf Proc IEEE Eng Med Biol Soc*, vol. 41, pp. 1788-1794, Jul 2019.
- [11] *Effects of Current on Human Beings and Livestock, CEI/IEC 60479-1: General Aspects, 5th Edition.*, IEC, 2016.
- [12] K. C. VerCauteren, M. J. Lavelle, and S. Hygnstrom, "Fences and deer-damage management: a review of designs and efficacy," *Wildlife Society Bulletin*, vol. 34, no. 1, pp. 191-200, 2006.
- [13] G. Bruinderink and E. Hazebroek, "Ungulate traffic collisions in Europe," *Conservation Biology*, vol. 10, no. 4, pp. 1059-1067, 1996.
- [14] S. L. Webb, K. L. Gee, S. Demarais, B. K. Strickland, and R. W. DeYoung, "Efficacy of a 15-strand high-tensile electric fence to control white-tailed deer movements," *Wildlife Biology in Practice*, vol. 5, no. 1, pp. 45-57, 2009.
- [15] M. Leblond, C. Dussault, J. Oellet, M. Poulin, R. Courtois, and J. Fortin, "Electric Fencing as a Measure to Reduce Moose-Vehicle Collisions," *The Journal of wildlife management*, vol. 71, no. 5, pp. 1695-1703, 2007.
- [16] L. L. Mastro, M. R. Conover, and S. N. Frey, "Deer-vehicle collision prevention techniques," *Human-Wildlife Interactions*, vol. 75, 2008.
- [17] *Household and similar electrical appliances – Safety – IEC 60335-2-76: Particular requirements for electric fence energizers*, 2006.
- [18] Whittaker, "Electric shock as it pertains to the electric fence," *Underwriter's Laboratories Bulletin of Research*, vol. 14, pp. 1-56, 1939.